

# TOTALLY OPEN: THE DIFFERENT OPTIONS

### Technical data:

Pressure: -1/+6 bar  
Temperature: -25/+200°C

### Materials:

Sight glass: Soda-lime glass  
DIN 8902  
Pressure-bearing steel parts: P 275 NH  
Other components: stainless steel  
Surface protection: electroplated coating Fe/Zn8C to DIN 50961  
Glasslining: Pfaudler-WWG, blue or white  
O-Ring: FEP-sheathed Viton\*

### Chemical resistance:

Only limited by glass and glasslining; refer to publication SB95-910-3GMM-01/02

### Approval:

Type approval by TUV, No. TUV.Db210/2 or TUV.Db.210/3

\* Other materials available optionally, including with FDA approval.

### Options

50W lamp  
Cleaning devices for flange connections  
Funnel tube in stainless steel No. 225 680



Description	Sizes	Part Number
<b>Fillook® 1</b> for stand-alone nozzle; fastened with split flange	DN100	FD-000
	DN110	FE-000
	DN150	FD-100
	DN200	FD-200
	DN250	FD-300
<b>Fillook® 2</b> for handholes at AE, DG and T; profiled ring fastening	DN100	FE-000
	DN150	FD-100
	DN200	FD-200
	DN250	FD-300
<b>Fillook® 3</b> Manhole cover with integrated filling hole cover	DN320/420	FD-600
	DN350/450	FD-700
	DN500	FD-800
	DN600	FD-900
<b>Fillook® 4</b> Manhole cover with integrated filling hole cover and additional Glasslook® Glasslook sight glass	DN320/420	FD-620
	DN350/450	FD-720
	DN500	FD-820
	DN600	FD-920
<b>Fillook® 5</b> Manhole cover with integrated filling hole cover and additional Glasslook® sight glass with 20W lamp	DN320/420	FD-630
	DN350/450	FD-730
	DN500	FD-830
	DN600	FD-930

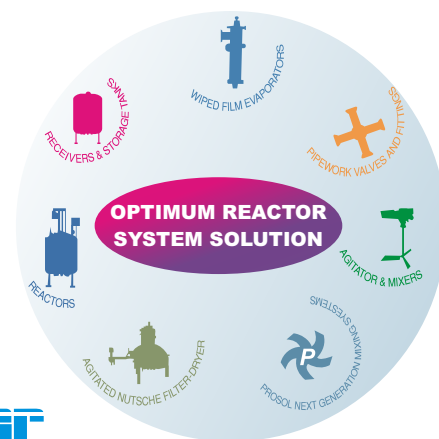

## GMM PFAUDLER LIMITED

**Corporate & Sales Office:**  
1001, Peninsula Towers,  
Peninsula Corporate Park,  
Ganpatrao Kadam Marg,  
Lower Parel, Mumbai - 400 013  
Tel.: +91-22 6650 3900  
Fax : +91-22 6650 3939  
E-mail : corporate@gmmpfaudler.co.in

**Registered Office & Works:**  
Vithal Udyognagar, Anand-Sojitra Road,  
KARAMSAD - 388 325  
Tel.: (02692) 230416 / 230516  
Fax : (02692) 236467  
E-mail : worksko@gmmpfaudler.co.in

**Regional Sales Offices:**  
**Ahmedabad:** Tel.: (079) 2754 6924, 2754 6822, Fax : (079) 2754 6894  
E-mail: sales.ahmd@gmmpfaudler.co.in  
**Chennai:** Tel.: (044) 2815 7906, Fax : (044) 2815 8249  
E-mail: sales.chn@gmmpfaudler.co.in  
**Hyderabad:** Tel.: (040) 2784 6646, 2772 1008, Fax : (040) 2784 6646  
E-mail: sales.hyd@gmmpfaudler.co.in  
**New Delhi:** Tel.: (011) 2361 1566, Fax : (011) 2362 3913  
E-mail: sales.del@gmmpfaudler.co.in  
**Vadodara:** Tel.: (0265) 235 4790, Fax : (0265) 231 1482  
E-mail: sales.vad@gmmpfaudler.co.in

# FILLOOK® FILLING HOLE COVERS MORE INSIGHT WITH THE RIGHT TWIST



www.gmmpfaudler.com

# FILLOOK®

## SIMPLY A CLEAN SOLUTION



**Three functions in one** - that's what you get with the Fillook® filling hole and handhole covers from GMM Pfaudler:

The fused-in Glasslook® sight glass ensures clear insight while offering increased safety. Reference is also made to our catalog 156-GMM-07/02 which describes the properties and advantages of our Glasslook® products.

**Easy filling/easy removal of product** is guaranteed by the quick-action closing system comprising four tommy screws made of stainless steel which do not require any additional tools. Funnel tubes facilitate filling of the reactor.

And last but not least, Pfaudler also supplies manhole covers with an integrated filling hole cover and a lamp - **three functions on one reactor nozzle**. Of special interest is Fillook® for the food processing and pharmaceutical industries, e.g. for quickly inspecting the inside of a reactor before and after cleaning processes.

### The added benefits of the Fillook® family:

- **Easy to clean** outside and inside, no contaminated spots at the sight glass, clearance-free
- **No gaskets** at the sight glass
- **CIP and GMP-approved**
- Optimized for **pharmaceutical applications**
- **Leakage-free** with high safety margins
- **Fracture-proof**, no total failure of the sight glass
- **Adjustable** opening angle

### Closing system with 3 tommy screws made of stainless steel

- **Quick-action closing system** of the filling hole cover
- Easy handling
- Can be opened and closed without tools
- Suitable for **pharmaceutical usage**
- Easy to clean

### Filling cover on manhole cover with second sight glass and lamp

- Lamp sight glass is **easily accessible**, easy to clean
- **One reactor nozzle remains free** for additional purposes.

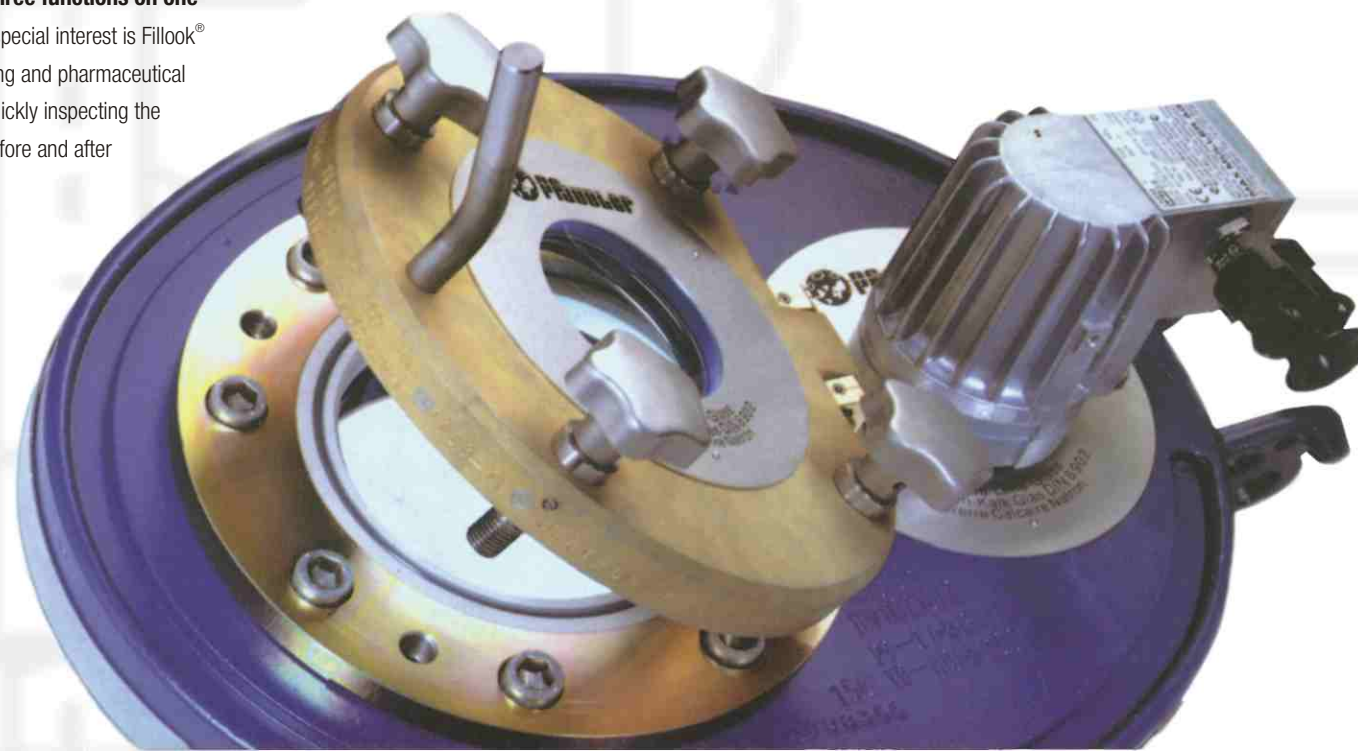

# FILLOOK® MAKES EVERYTHING EASIER

The different Fillook® design options have positive effects on many aspects of reactor works. Cleaning is easier. There are fewer screws and fastening elements.

The number of gaskets is reduced. The total number of parts required is lower. And besides, the process becomes more safe.

In order to meet all demands, the Pfaudler Fillook® filling hole covers are available in different designs:

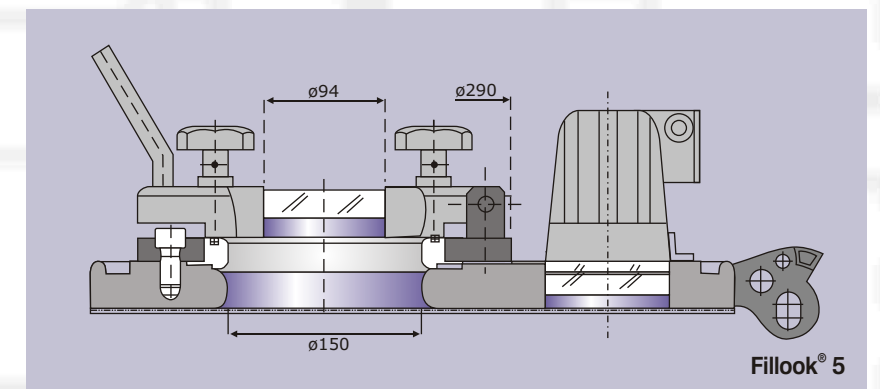
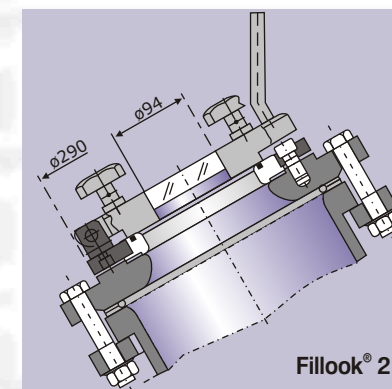
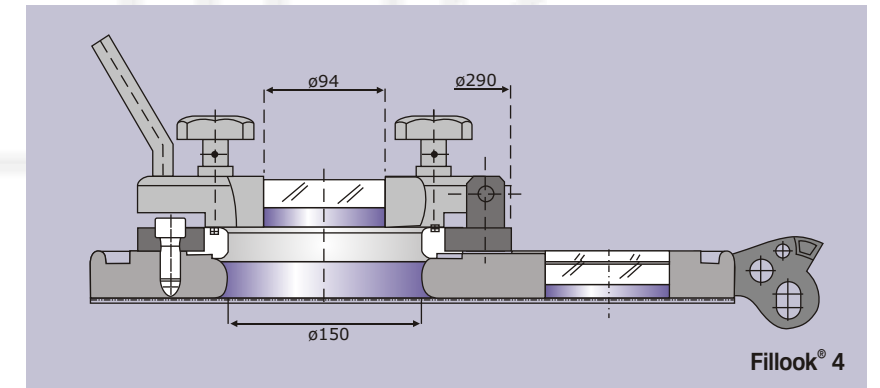
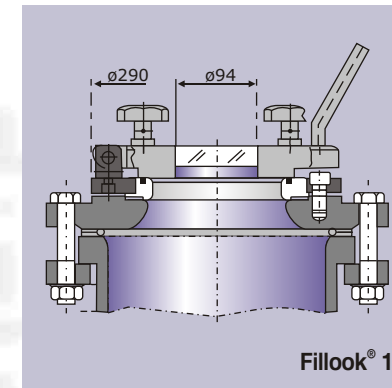
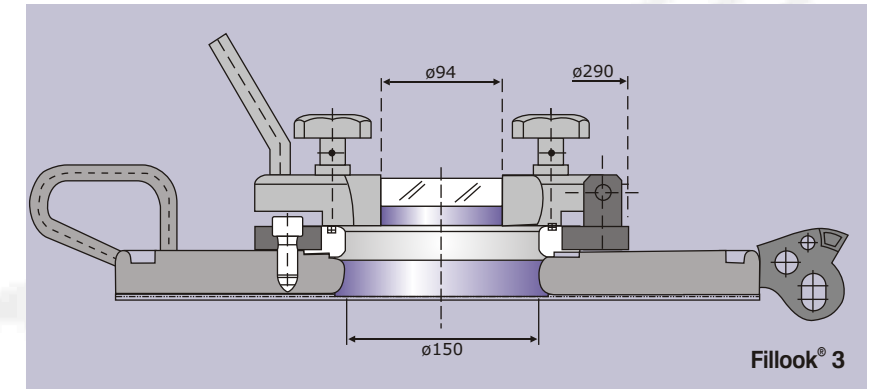

**Fillook® 1** is fastened to the nozzle with a split flange.

**Fillook® 2** for handholes on reactor types AE, DG and T is fastened with profiled ring.

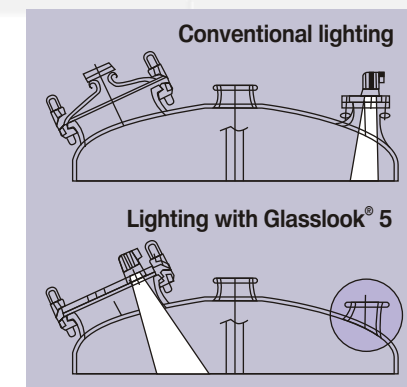

**Fillook® 3** is a filling hole cover mounted on a manhole cover.

**Fillook® 4** is similar to Fillook® 3, but has an additional Glasslook® sight glass.

**Fillook® 5** is additionally equipped with a lamp unit at the second sight glass.

- Non-dazzling insight, non-dazzling illumination; direction of light = viewing direction.
- No shading-off by agitator shaft.

\* The actual design may slightly differ from the one shown.