

## GENERAL INFORMATION

Heat exchangers based on borosilicate glass 3.3 have the advantage of transparency and high corrosion resistance as important features for various applications in the chemical and pharmaceutical industries. Just about every process involving fluid media involves heat being added or removed.

NORMAG therefore offers a wide range of heat exchangers to suit various applications, which are all designed and optimised with respect to the process requirements. By way of example of the variety of types of apparatus offered, the pictures below depict a coil type heat exchanger, a shell and tube heat exchanger and a thin film evaporator.



Coil type heat exchanger  
HC...-K



Shell and tube heat exchanger  
HST...-K



Thin film evaporator  
HTF...-H...

The well-established design distinguish themselves with respect to their universal corrosion resistance and their high level of heat transfer performance. The materials used, such as borosilicate glass 3.3, tantalum, titanium, silicone carbide, PTFE and FFKM etc. ensure high levels of operational safety when working with aggressive media. Hastelloy or stainless steel are also used, if corrosion conditions etc. permit.

Our entire selection of standard deliverable components is detailed on the following pages. Special designs that are available upon request are mentioned alongside the respective product descriptions. If you require any of these special designs, or have any other special requirements, please speak to our experts.

For pharmaceutical applications, GMP-compliant installations using the inert materials borosilicate 3.3 or SiC combined with FDA-certified materials such as PTFE are possible. A dead space minimized design for complete draining as well as the possibility for simple and effective cleaning is provided by the design of various apparatuses, for example coil exchangers in their standard design or with specific adjustments. Furthermore, the use of the material Boro 3.3 avoids the build-up of deposits in areas that come into contact with the product, and it is also possible to provide heat exchangers whose external design is suitable for clean room conditions.

In the section's appendix, you will find options such as transparent coatings to protect the heat exchangers.

Detailed facts and information concerning some of the topics which follow can be found in chapter 10, 'Technical information'.

Upon request, and on provision of the necessary data, we would be pleased to present you with a selection of apparatus along with a design calculation. To do so, please send us a completed copy of the questionnaire that can be found at the end of the chapter, or contact our experienced engineers directly.

With regards to introducing the cooling or heating media, please pay attention to the following 'Notes on the use of coil type heat exchangers' and other apparatus, also by means of analogy. With regard to the introduction of heating media, the following diagram depicts typical connectivity for the various applications.

Figure 5.1: Typical connectivity for heating media in coil type heat exchangers

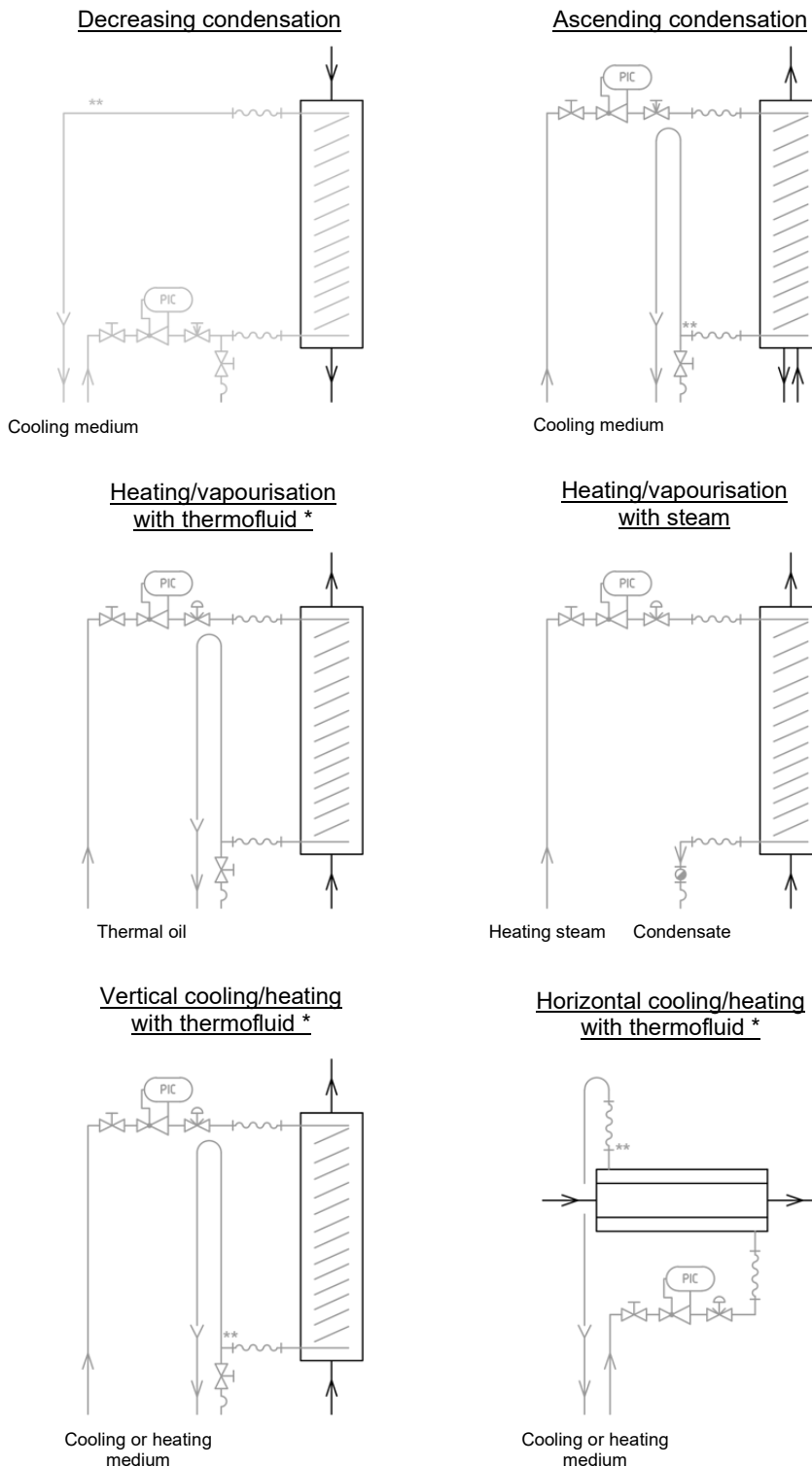

\* When using a thermostat, connectivity is simplified on the basis of the thermostat's controls and fuse protection  
 \*\* When heating the cooling medium to boiling temperature, the use of an FS- or TS+ monitoring system is recommended

## COIL TYPE HEAT EXCHANGER

Coil type heat exchangers are manufactured entirely of highly corrosion-resistant borosilicate glass 3.3. The coil batteries are melted to the shell, thus providing seal-free separation of the product and the heating medium, along with a consistently smooth, metal-free surface. When assembled vertically, the apparatus is able to drain, meaning that it is very well-suited to processes that involve regular changes of product, or pharmaceutical applications, among others. A further advantage is that, for a wide range of heating medium temperatures, no insulation of the apparatus is required, which avoids impermissible wall temperatures or condensate.

The equipment is generally used for transferring heat between fluid media. The main areas of application are the condensation and cooling/heating of liquids. The following section provides information on the permitted operating conditions, technical data relating to the selection and sizing and general notes on the use of heat exchangers.

Our coil type heat exchangers are available in the following variants: HC, HI, HL, HG, HCR and HCH. At the end of the section, you will find a list of available options relating to the coil type heat exchangers.

### Approved operating conditions

For all types of heat exchangers, the permitted operating pressure in the coil battery is 3 bar. Please also pay attention to the following 'Notes on the use of coil type heat exchangers'.

The permitted operating pressure in the shell corresponds to the entries in chapter 10, 'Technical information' of the catalogue, in relation to the nominal values and temperature difference at  $\Delta T$ /thermal shock resistance. The borosilicate glass 3.3 coil heat exchanger's permitted operating temperature is  $-50$  to  $+200^{\circ}\text{C}$  with respect to the permitted temperature difference of  $\Delta T = 100$  K via the exchange tube.

If you have any special requirements, please contact our experts.

### Technical data

The standard values contained in table 5.1 for the heat transfer coefficient  $k$  can be taken as an approximate basis for calculating exchange areas. The heat transfer coefficient is significantly determined by the medium, flow velocity and other properties such as fouling tendency. We would be pleased to carry out an exact apparatus calculation according to your specific operating conditions.

Table 5.1 Standard values for heat transfer  $k$  in coil type heat exchangers of type HC

k-value [W/m <sup>2</sup> K]	Medium	
	in the coil [-]	in the shell [-]
<b>200–550</b>	Cooling water	Solvent/Water vapour, condensing
<b>80–250</b>	Thermal oil	Solvent/Water vapour, condensing
<b>20–60</b>	Cooling water	Gas (non-condensing)
<b>20–50</b>	Thermal oil	Gas (non-condensing)
<b>120–350</b>	Cooling water	Solvent/Aqueous solution (non-boiling)
<b>50–200</b>	Thermal oil	Solvent/Aqueous solution (non-boiling)

The following figure 5.2 and table 5.2 show information on pressure loss, along with performance data for estimating the required heat transfer surface, on the basis of the HC type.

Figure 5.2: Pressure loss in the coil battery of coil type heat exchanger type HC

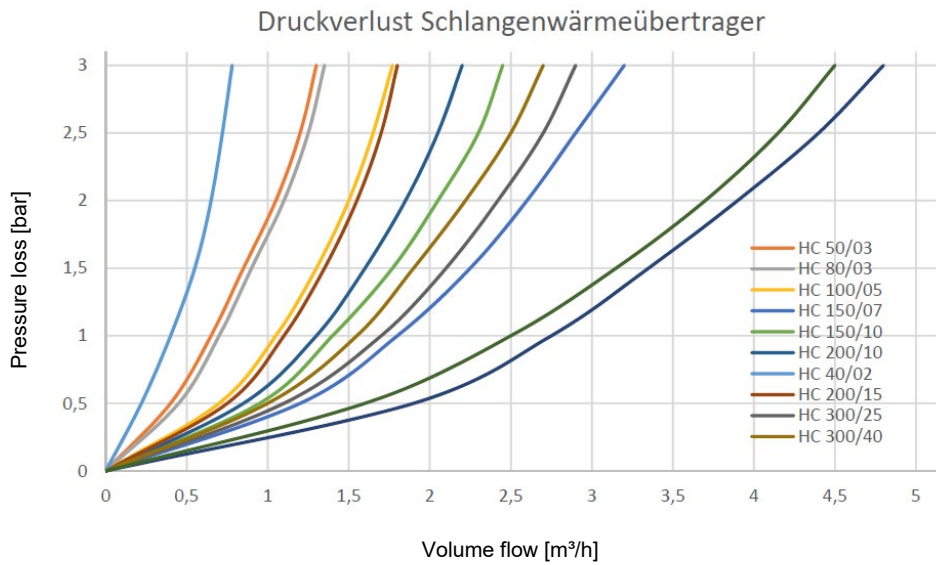

Table 5.2 Coil type heat exchanger type HC: technical data

Area [m <sup>2</sup> ]	Free cross-section		Filling volume		Condensation <sup>1)</sup>		Item no.
	Coils [mm <sup>2</sup> ]	Shell [cm <sup>2</sup> ]	Coils [l]	Shell [l]	Cooling water [l/h]	Distillate [l/h]	
0.2	47.9	2.8	0.19	0.9	400	13	HC 040/02-K
0.4	112	9.9	0.52	2.4	700	20	HC 050/03-K
0.4	112	9.9	0.52	2.5	700	20	HC 080/03-K
0.5	260	16	1	3.8	1,300	34	HC 100/05-K
0.8	393	30	1.8	8.9	2,100	55	HC 150/07-K
1.3	393	30	3.0	12	1,800	89	HC 150/10-K
1.0	525	80	2.2	13	1,600	69	HC 200/10-K
1.7	525	80	4.0	19	1,400	107	HC 200/15-K
2.5	290	250	6	32	1,700	140	HC 300/25-K
4.0	290	250	10	40	1,500	185	HC 300/40-K
4.0	480	380	12	56	2,800	250	HC 400/40-K
5.0	480	380	15	63	2,600	300	HC 400/50-K

1) Sample data for condensation with water as cooling medium, in coil battery at 1 bar pressure loss and typical solvent to be condensed with 600 W/m<sup>2</sup>K, plus partly limited by typical temperature difference and achievable heat transfer during condensation.

**Notes on the use of coil type heat exchangers made from borosilicate glass 3.3**

- Figure 5.1 shows examples of the connections for coil type heat exchangers for various types of use. Depending on the particular use, there are numerous other connection options. When using any of these, please observe the following conditions which apply to the use of standard apparatus.
- Cooling and heating media/coil battery connections should be made using tubing or bellows and should be tension-free.
- Ensure that there is free, unpressurised discharge at the tube side/heating medium outlet, provided that no other steps can be taken to ensure that the permitted operating pressure cannot be exceeded.
- When connecting the tubing, for the majority of applications we recommend the use of 90° tube connectors, to reduce the bending moment on the connecting pieces. Ensure that there is weight compensation of the tubes on the respective connecting pieces.
- To avoid pressure surges in the coil battery, ensure that suitable slowly opening valves are used.
- Horizontal construction, or slightly sloping assembly, is only possible to a nominal width of DN 150.
- Condensable vapours, for example heating steam, can only be used in the heat exchanger's coil batteries up to a nominal width of DN 150. Always ensure that the permissible operating conditions are adhered to and that the condensate is able to flow without pressure or backwater.
- In order to avoid damage to the coils, no fluid media must be allowed to vaporise in the coil batteries. By way of example, for condensates with product-side condensation temperatures that are close to or which exceed the cooling medium's boiling temperature, a sufficient flow of cooling liquid is required to avoid them being heated to boiling temperature. For this instance, optional flow monitors and a temperature monitor for the return flow should be used.
- If there is danger of frost, the spirals should be completely emptied.
- Insulation to avoid condensed water, or as protection against contact at temperatures that are too high, may be required as per chapter 10. In such cases, this only applies to the shell side of the heat exchanger. Usually, even at extremely high heating medium temperatures in the coil battery, there is no need for insulation.
- If the heat exchanger's connecting pieces, usually those of coil type heat exchangers, are labelled with IN/OUT, ensure that you pay attention to these directions when assembling the feeders.
- When assembling the heat exchangers vertically, ensure that the writing is legible and not upside down.
- Heat exchangers can be connected parallel or in series, in order to achieve larger exchange areas.
- The heat exchangers can be cleaned with suitable non-corrosive chemicals. Mechanical cleaning is not permitted.

**COIL TYPE HEAT EXCHANGER, UNIVERSAL**

Our coil type heat exchangers are available in the universal variant HC and various special designs as options. At the end of the chapter, you will find a list of available options relating to the coil type heat exchangers. Examples for options are:

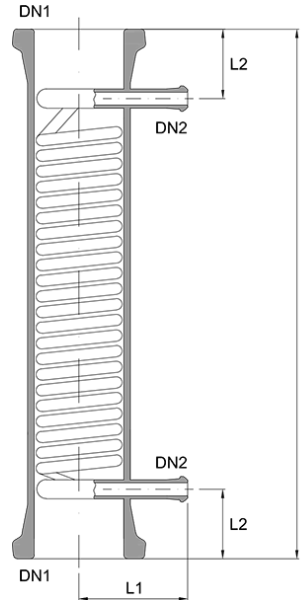

Coil type heat exchanger  
HC...-K

**Descriptions:**

- Heat exchanger, PF system, dimensions of the old design:
- Heat exchanger, PF system, conductive coating:
- Heat exchanger, PF-system, with 2.1 material certificate:

**Item number**

- HC...-K-O10
- HC...-K-C3
- HC...-K-Z2

**Example**

- HC 150/07-K-O10
- HC 300/40-K-C3
- HC 300/40-K-Z2

Area [m <sup>2</sup> ]	DN1	DN2	L [mm]	L1 [mm]	L2 [mm]	Item no.
0.2	40	15	610	75	95	<b>HC 040/02-K</b>
0.4	50	15	610	100	95	<b>HC 050/03-K</b>
0.4	80	15	610	100	95	<b>HC 080/03-K</b>
0.3	100	15	450	125	75	<b>HC 100/03-K-O10</b>
0.5	100	15	610	125	95	<b>HC 100/05-K</b>
0.6	150	25	525	175	85	<b>HC 150/06-K-O10</b>
0.8	150	25	610	150	100	<b>HC 150/07-K</b>
1.3	150	25	840	150	100	<b>HC 150/10-K</b>
1.0	200	25	500	175	95	<b>HC 200/10-K</b>
1.2	200	25	575	175	95	<b>HC 200/15-K-O10</b>
1.7	200	25	725	175	95	<b>HC 200/15-K</b>
2.5	300	25	600	275	100	<b>HC 300/25-K</b>
4.0	300	25	825	275	100	<b>HC 300/40-K</b>
3.8	400	25	600	350	110	<b>HC 400/40-K</b>
4.8	400	25	700	350	110	<b>HC 400/50-K</b>

**IMMERSION HEAT EXCHANGERS, BOROSILICATE GLASS 3.3 AND STAINLESS STEEL**

These immersion heat exchangers are mostly used for cooling and heating containers at the bottom. Cooling, heating and vaporising are all possible. Cooling water, thermal oil and also heat steam can all be used as tempering media. The immersion heat exchanger is drainable at both the shell and tube sides. As well as the design in glass HIG, the stainless steel variant HIS is also offered as standard.

At the end of the chapter, you will find a list of available options relating to immersion heat exchangers. Examples are:

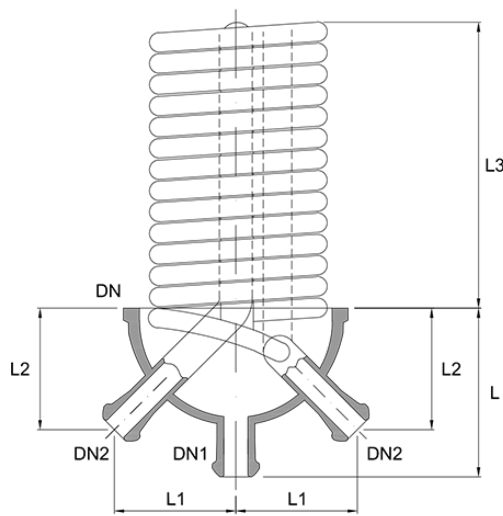

Glass immersion heat exchangers  
HIG...-K

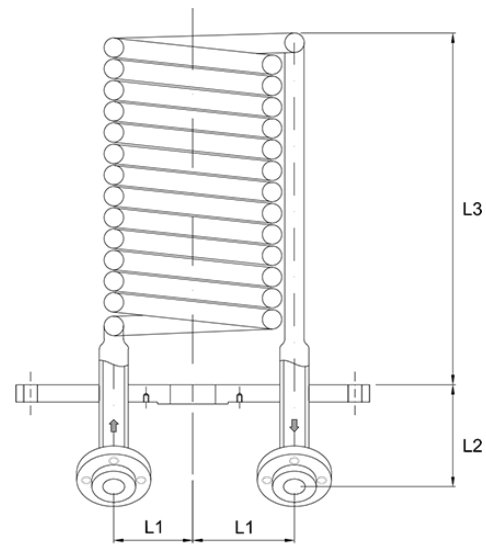

Stainless steel immersion heat exchangers  
HIS...

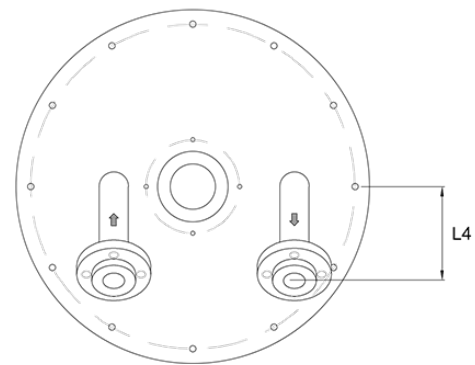

**Descriptions:**

Immersion heat exchanger, PF, conductive coating:

Immersion heat exchanger, PF, with 2.1 material certificate:

Immersion heat exchanger, PF, with outlet nozzles DN 40:

Immersion heat exchanger, PF, with minimal dead space nozzles DN 40:

**Item number**

HIG...-K-C3

HIG...-K-Z2

HIG...-K-O1

HIG...-K-O2

**Example**

HIG 150/06-K-C3

HIG 150/06-K-Z2

HIG 150/06-K-O1

HIG 150/06-K-O2

Area [m <sup>2</sup> ]	DN	DN1	DN2	L [mm]	L1 [mm]	L2 [mm]	L3 [mm]	L4 [mm]	Item no.	Item no.
									glass	stainless steel <sup>1)</sup>
0.3	100	25	15	175	79	106	260	-	<b>HIG 100/03-K</b>	
0.6	150	25	25	185	113	133	290	-	<b>HIG 150/06-K</b>	
				-	60	156	235	106		<b>HIS 150/06-K</b>
0.7	200	25	25	175	144	144	260	-	<b>HIG 200/07-K</b>	
				-	60	156	450	106		<b>HIS 200/07-K</b>
1.0	200	25	25	175	144	144	355	-	<b>HIG 200/10-K</b>	
				-	60	156	655	106		<b>HIS 200/10-K</b>
1.0	300	25	25	225	172	172	260	-	<b>HIG 300/10-K</b>	
				-	85	156	325	106		<b>HIS 300/10-K</b>
1.5	300	25	25	225	172	172	355	-	<b>HIG 300/15-K</b>	
				-	85	156	495	106		<b>HIS 300/15-K</b>

- 1) Stainless steel immersion heat exchangers of type HIS have connecting flanges in accordance with EN 1092-1, PN 10 for the DN2 tempering connectors. All other connecting pieces have a connector for KF glass flanges.



LIQUID COOLERS

Liquid coolers are predominantly used as after coolers for distillate, and are integrated into the distillate pipe. In order to compensate for pressure loss in the liquid coolers, we recommend a supply height of at least 0.3m. The maximum recommended distillate flow rate, based on water, is shown in the following table. At the tube side, the liquid cooler is drainable due to the vertical assembly. Horizontal assembly is not recommended, due to the difficulty in ventilating, the non-drainable position and heavier strain on the coil battery. At lower flow rates, it may be necessary to use a siphon on the distillate pipe to ensure that liquids are filled with sufficient heat transfer.

At the end of the chapter, you will find a list of available options relating to liquid coolers. Examples are:

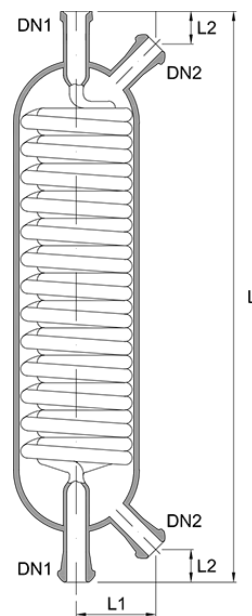

Liquid cooler  
HL....-K

**Descriptions:**

Liquid cooler, PF system, conductive coating:

Liquid cooler, PF system, with 2.1 material certificate:

**Item number**

HL....-K-C3

HL....-K-Z2

**Example**

HL 025/006-K-C3

HL 025/06-K-Z2

Area [m <sup>2</sup> ]	DN	DN1	DN2	L [mm]	L1 [mm]	L2 [mm]	V <sup>1)</sup> [l/h]	Item no.
0.03	65	15	15	250	79	30	200	<a href="#">HL 015/003-K</a>
0.06	65	15	15	350	79	30	200	<a href="#">HL 015/006-K</a>
0.1	65	15	15	500	79	30	200	<a href="#">HL 015/010-K</a>
0.2	100	25	25	475	85	40	400	<a href="#">HL 025/020-K</a>
0.3	100	25	25	550	85	40	400	<a href="#">HL 025/030-K</a>
0.3	100	25	25	500	125	100	400	<a href="#">HL 025/030-K-O10</a>
0.5	150	25	25	550	105	45	700	<a href="#">HL 025/050-K</a>
1.0	150	25	25	750	105	45	700	<a href="#">HL 025/100-K</a>

1) The information shown is based on water at 15°C and a pressure loss in accordance with a supply height of 0.3m max.

VENT CONDENSER / COMPACT CONDENSER

Vent condensers are used to further cool waste gases and therefore separate distillate after running through the main condensers, but also as main condensers in smaller, low-height systems.

Horizontal assembly is not recommended, due to the difficulty in ventilating, the non-drainable position and heavier strain on the coil battery. With lower available heights, the HGH type can be used with waste gas outlet nozzles at the side.

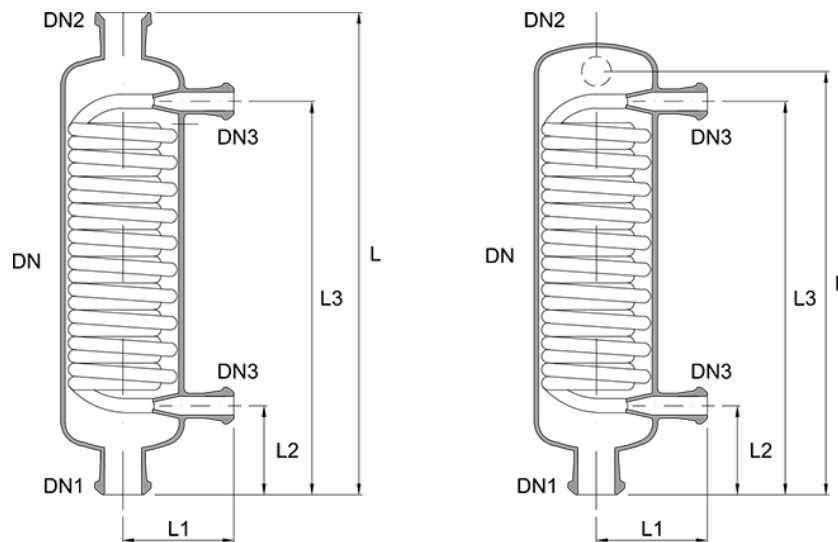

Vent condenser, vertical, HGK...-K

Vent condenser, horizontal outlet, HGH...-K

Descriptions:

Post-cond. / compact cond., PF system, conductive coating:

Item number

HGV...-K-C3

Example

HGV 100/050-15-K-C3

Post-cond. / compact cond., PF system, with 2.1 material certificate:

HGV...-K-Z2

HGV 100/050-15-K-Z2

Area [m <sup>2</sup> ]	DN [mm]	DN1	DN2	DN3	L [mm]	L1 [mm]	L2 [mm]	L3 [mm]	L4 [mm]	Item no.
0.3	80	50	25	15	610	100	95	515	-	<a href="#">HGV 050/025/03-K</a>
0.3	80	50	25	15	525	100	95	515	100	<a href="#">HGH 050/025/03-K</a>
0.5	100	50	25	15	625	125	110	515	-	<a href="#">HGV 050/025/05-K</a>
0.5	100	50	25	15	550	125	110	515	125	<a href="#">HGH 050/025/05-K</a>
0.6	100	25	25	15	800	125	125	550	-	<a href="#">HGV 025/025/06-K-O10</a>
0.6	100	50	50	15	800	125	125	550	-	<a href="#">HGV 050/050/06-K-O10</a>
1.0	150	80	25	25	725	150	125	600	-	<a href="#">HGV 080/025/10-K</a>
1.0	150	80	25	25	625	150	125	600	150	<a href="#">HGH 080/025/10-K</a>
1.5	200	100	50	25	725	175	120	605	-	<a href="#">HGV 100/050/15-K</a>
1.5	200	100	50	25	625	175	120	605	175	<a href="#">HGH 100/050/15-K</a>

REFLUX CONDENSER, SLOPING

The sloping condenser is used as a reflux condenser in smaller, low-height systems. Exhaust vapours are introduced vertically via the DN1 nozzle, whilst waste gas exits via the DN2 nozzle and the distillate flows back through the DN1 nozzle. The cooling medium is introduced and channelled out of the DN3 nozzle, and does not run off freely.

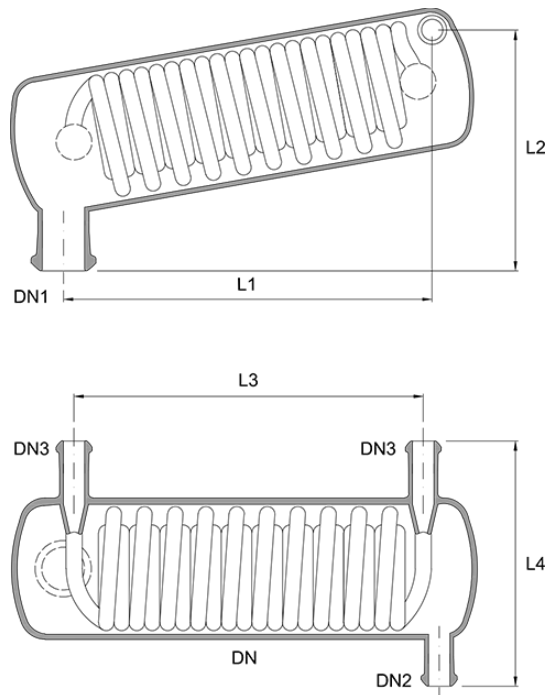

Reflux condenser HCR....-K

Descriptions:

Reflux condenser, sloping, PF system, conductive coating:

Item number

HCR....-K-C3

Example

HCR 100/07-K-C3

Reflux condenser, sloping, PF system, with 2.1 material certificate:

HCR....-K-Z2

HCR 100/07-K-Z2

Reflux condenser, sloping, PF system, DN2/DN3 mirrored:

HCR....-K-O3

HCR 100/07-K-O3

Area [m <sup>2</sup> ]	DN [mm]	DN1	DN2	DN3	L1 [mm]	L2 [mm]	L3 [mm]	L4 [mm]	Item no.
0.2	80	40	15	15	610	175	480	175	<a href="#">HCR 040/03-K</a>
0.3	80	50	15	15	610	200	480	195	<a href="#">HCR 050/03-K</a>
0.8	150	50	15	15	610	200	480	215	<a href="#">HCR 050/07-K</a>
0.3	100	80	15	15	610	225	480	235	<a href="#">HCR 080/03-K</a>
0.8	150	80	25	25	610	250	480	280	<a href="#">HCR 080/07-K</a>
1.3	150	80	25	25	840	250	650	280	<a href="#">HCR 080/10-K</a>
0.8	150	100	25	25	500	275	400	325	<a href="#">HCR 100/07-K</a>
1.3	150	100	25	25	725	275	550	325	<a href="#">HCR 100/10-K</a>

CONDENSER, HORIZONTAL

Similar to the sloping reflux condenser, the flow rate condenser is used with smaller, low-height systems. However, in this design, the distillate is discharged via a separate nozzle, in the same current as the waste gas. Exhaust vapours are introduced vertically via the DN1 nozzle, whilst waste gas exits via the DN2 nozzle and the distillate runs off through the DN3 nozzle. The cooling medium is introduced and channelled out of the DN4 nozzle, and does not run off freely.

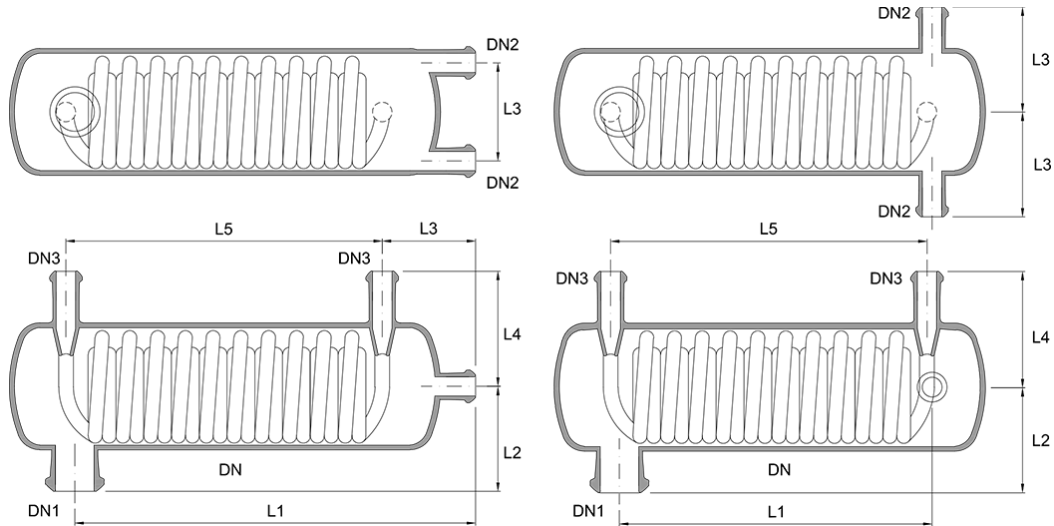

Horizontal condenser  
HCH...-K

Horizontal condenser, vertical connections  
HCH...-K-O5

Descriptions:

- condenser, horizontal, PF system, conductive coating:
- condenser, horizontal, PF system, with 2.1 material certificate:
- condenser, horizontal, PF system, DN4 mirrored:
- condenser, horizontal, PF system, vertical outlet connections:

Item number	Example
HCH...-K-C3	HCH 100/07-K-C3
HCH...-K-Z2	HCH 100/07-K-Z2
HCH...-K-O3	HCH 100/07-K-O3
HCH...-K-O5	HCH 100/07-K-O5

Area [m <sup>2</sup> ]	DN [mm]	DN1	DN2	DN3	L1 [mm]	L2 [mm]	L3 [mm]	L4 [mm]	L5 [mm]	Item no.
0.3	80	40	15	15	610	75	95	95	470	<a href="#">HCH 040/03-K</a>
0.3	80	50	15	15	580	100	95	95	440	<a href="#">HCH 050/03-K</a>
0.8	150	50	25	25	610	100	95	95	470	<a href="#">HCH 050/07-K</a>
0.3	100	80	15	15	580	125	80	80	440	<a href="#">HCH 080/03-K</a>
0.8	150	80	25	25	610	150	100	100	470	<a href="#">HCH 080/07-K</a>
1.3	150	80	25	25	840	150	100	100	700	<a href="#">HCH 080/10-K</a>
0.8	150	100	25	25	610	175	95	95	470	<a href="#">HCH 100/07-K</a>
1.3	150	100	25	25	840	175	95	95	700	<a href="#">HCH 100/10-K</a>

**SHELL AND TUBE HEAT EXCHANGER**

Shell and tube heat exchangers are used as an alternative to spiral heat exchangers; either as condensers or for transferring heat between fluid media. The standard design features shell and tube heat exchangers made from corrosion-resistant borosilicate glass 3.3 and PTFE, and optionally, with SiC and elastomer, which is similar to PTFE, on the product side. The advantages of using SiC are the compact construction, which is due to a smaller exchange area being required, along with improved heat transfer and the material being easy to maintain and repair, plus increased operating safety.

In the standard design, the PTFE tube bottom is joined to the borosilicate glass tubes with a cutting ring, as shown in the following diagram. One of these is pulled individually onto every single tube, to seal it. This ensures that optimal sealing is achieved. For heat exchangers with SiC tubes and a leakage chamber, an additional seal is created using two O-rings made from elastomer, a material similar to PTFE. This ensures that the cooling and heating medium and product side cannot mix. To improve the heat exchange, and to avoid vibrations, PTFE baffles are used.

- 1 – PTFE cutting ring
- 2 – PTFE tube bottom
- 3 – Heat exchange tube, borosilicate glass 3.3

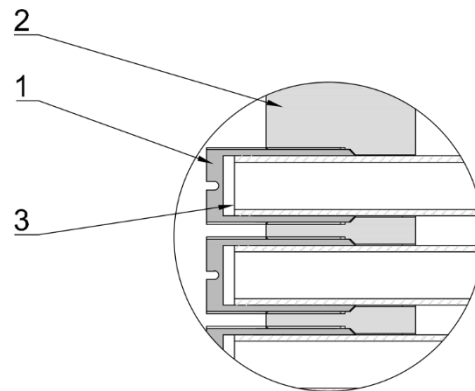

Depending on the type, the following materials are used:

- Tubes: Borosilicate glass 3.3, SiC, special materials on request
- Shell: Borosilicate glass 3.3, enamel
- Tube bottoms/seal/baffles: PTFE, FFKM, FEP
- Spacer bar: Borosilicate glass 3.3
- Covers: 1.4571, borosilicate glass 3.3

The following values can be taken as a basis for the approximate design of the shell and tube heat exchanger:

		<i>liquid-liquid</i>		<i>liquid-condensing</i>	
		Water-water	Water-organic	Water-water	Water-organic
Glass	[W/m <sup>2</sup> K]	300–600		250–500	500–650 400–600
SiC	[W/m <sup>2</sup> K]	600–1800	500–1400	1200–3000	750–2000

Pressure loss in the shell and tube heat exchanger depends largely on the cooling and heating medium, the tube length and the quantity. Pressure loss at the side of the tube which the liquid flows through should be a maximum of 1 bar. The respective velocity in the tubes should be maximum 1 m/s.

For more detailed information, please contact our specialists.

The following specifications and options are available for the HST shell and tube heat exchanger:

<b>Description:</b>		<b>Item number</b>	<b>Example</b>
Shell and tube heat exchanger type HST		HST NW A/SNW/CD-F	HST 200/080/744/GS1-K
with	NW Nominal width heat exchanger		DN 200
	A Exchange area in 10 x m <sup>2</sup> (refers to external diameter of the WT tubes, standard Ø14mm)		8.0m <sup>2</sup>
	SNW Nominal widths for nozzles DN2 to DN4, arranged according to diagram with following width coding		Nozzle DN2 = DN 150 Nozzle DN3 = DN 50 Nozzle DN4 = DN 50
	Code 0 1 2 3 4 5 6 7 8 9		
	NW none 15 25 40 50 80 100 150 200 300		
	CD Cover design:		
	1st position Tube: glass (G), SiC (S) or special material (X)		Glass tube Ø14 x 1.5
	2nd position: Glass cover (G) or 1.4571 (S)		Stainless steel cover
	3rd position: passes of glass or 1.4571 cover, choice of one (1), two (2) or three (3) passes		single pass
	F Glass flange type in PF (P) and KF (K) system		PF flange system

<b>Descriptions (selection):</b>	<b>Item number</b>	<b>Example</b>
HST, glass, conductive coating:	HST....-C3	HST 200/080/744/GS1-K-C3
HST, PTFE, conductive with earthing:	HST....-M2	HST 200/080/744/GS1-K-M2
HST, with FDA material certificates:	HST....-Z1	HST 200/080/744/GS1-K-Z1
HST, vertical design:	HST....-OST1	HST 200/080/744/GS1-K-OST1
HST, with leakage chamber:	HST....-OST2	HST 200/080/744/GS1-K-OST2
HST, with baffle plate steam:	HST....-OST3	HST 200/080/744/GS1-K-OST3
HST, with enamel shell:	HST....-OST4	HST 200/080/744/GS1-K-OST4
HST, in clean room design:	HST....-OST5	HST 200/080/744/GS1-K-OST5
HST, with turbulence promoter:	HST....-OST6	HST 200/080/744/GS1-K-OST6
HST, special design:	HST....-X...	HST 200/080/744/GS1-K-X001

Special designs are allocated a consecutive X number by NORMAG for the respective area of application. The following all count as special designs: amended arrangement, type and diameter of nozzles; amended quantity and arrangement of baffles; use of special materials such as Hasteloy or graphite; U-tube designs for stainless steel tubes; tilt angles. Please speak to us to discuss any special requirements you may have.

For standard designs, depending on the nominal width, the following measurements and operating conditions apply. Additional general data that also depends on the nominal width is given on page 6.13.

	L6	L7	L8	L10	Tubes	ØTube	Tube	Perm. Op. press.	Perm. Op. temp.	
	[mm]	[mm]	[mm]	[mm]	[pcs]	[mm]		Tube	Shell	
								[BarG]	[BarG]	[°C]
DN100	-	208	574	200	13	Ø14 x 1.5	Glass	-1/+3	-1/+2	-50/+150
							SiC	-1/+6	-1/+2	-50/+50
DN150	55	208	574	200	37	Ø14 x 1.5	Glass	-1/+3	-1/+2	-50/+150
							SiC	-1/+6	-1/+2	-50/+50
DN200	77	243	677	200	61	Ø14 x 1.5	Glass	-1/+3	-1/+1	-50/+150
							SiC	-1/+3	-1/+1	-50/+150
DN300	112	295	897	200	163	Ø14 x 1.5	Glass	-1/+3	-1/+1	-50/+150
							SiC	-1/+3	-1/+1	-50/+150
DN400	-	574	620	200	301	Ø14 x 1.5	Glass	-1/+2	-1/+0.5	-50/+150
							SiC	-1/+3	-1/+0.5	-50/+100

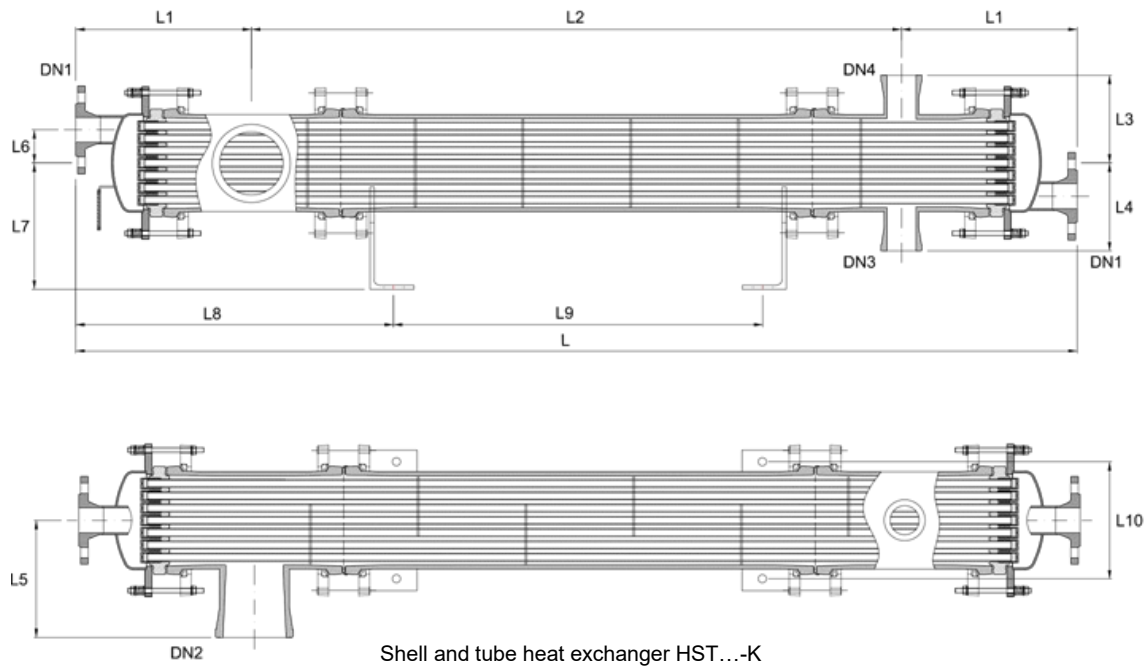

Specific dimensions for the standard shell and tube heat exchanger are listed below. These are based on the type with glass tubes and 1-Kass stainless steel cover:

Area [m²]	DN	DN1*	DN2	DN3	DN4	L [mm]	L1 [mm]	L2 [mm]	L3 [mm]	L4 [mm]	L5 [mm]	Item no.
0.6	100	25	50	25	25	1,300	250	800	125	125	125	<a href="#">HST 100/006/422/GS1-K</a>
1.0	100	25	50	25	25	1,800	250	1,300	125	125	125	<a href="#">HST 100/010/422/GS1-K</a>
1.5	100	25	80	25	25	2,850	275	2,300	125	125	125	<a href="#">HST 100/015/522/GS1-K</a>
2.5	150	40	100	50	50	1,710	300	1,110	175	175	200	<a href="#">HST 150/025/644/GS1-K</a>
3.2	150	40	100	50	50	2,210	300	1,610	175	175	200	<a href="#">HST 150/032/644/GS1-K</a>
4.0	150	40	100	50	50	2,710	300	2,110	175	175	200	<a href="#">HST 150/040/644/GS1-K</a>
5.0	150	40	100	50	50	3,210	300	2,610	175	175	200	<a href="#">HST 150/050/754/GS1-K</a>
5.0	200	50	150	80	50	2,260	375	1,510	200	175	250	<a href="#">HST 200/050/754/GS1-K</a>
6.3	200	50	150	80	50	2,760	375	2,010	200	175	250	<a href="#">HST 200/063/754/GS1-K</a>
8.0	200	50	150	80	50	3,260	375	2,510	200	175	250	<a href="#">HST 200/080/754/GS1-K</a>
10.0	200	50	150	80	50	3,760	375	3,010	200	175	250	<a href="#">HST 200/100/754/GS1-K</a>
10.0	300	80	150	100	80	1,760	475	810	300	275	300	<a href="#">HST 300/100/864/GS1-K</a>
12.5	300	80	150	100	80	2,260	475	1,310	300	275	300	<a href="#">HST 300/125/864/GS1-K</a>
16.0	300	80	150	100	80	2,760	475	1,810	300	275	300	<a href="#">HST 300/160/864/GS1-K</a>
20.0	300	80	150	100	80	3,260	475	2,310	300	275	300	<a href="#">HST 300/200/864/GS1-K</a>
25.0	300	80	150	100	80	3,760	475	2,810	300	275	300	<a href="#">HST 300/250/864/GS1-K</a>
25.0	400	80	200	150	80	2,360	525	1,310	350	350	350	<a href="#">HST 400/250/974/GS1-K</a>
35.0	400	80	200	150	80	2,860	525	1,810	350	350	350	<a href="#">HST 400/350/974/GS1-K</a>
45.0	400	80	200	150	80	3,360	525	2,310	350	350	350	<a href="#">HST 400/450/974/GS1-K</a>

\* Flange type according to EN 1092-1 PN 10. Other flange types available on request.

In addition to the main measurements and permissible operating conditions, the following apparatus and operating data also applies to the standard shell and tube heat exchangers.

	Free cross sect.			Cool./heat. medium		Weight*	Passes
	Tubes	Shell	Baffles	at 0.5 m/s in tube			
	Clearance						
	[10 <sup>-2</sup> m <sup>2</sup> ]	[10 <sup>-2</sup> m <sup>2</sup> ]	[10 <sup>-2</sup> m <sup>2</sup> ]	[mm]	[m <sup>3</sup> /h]	[kg]	[-]
DN100	0.12	0.6	0.2	300	2.2	29–53	1
	0.04				0.7		3
DN150	0.35	1.2	0.4	400	6.4	52–71	1
	0.12				2.1		3
DN200	0.58	2.2	0.8	500	10.4	84–109	1
	0.19				3.4		3
DN300	1.55	4.6	1.6	500	27.9	187–248	1
	0.52				9.7		3
DN400	2.98	8.0	2.8	500	51.0	215–325	1
	0.99				17.0		3

\* The weights given are unloaded weights for the specified standard designs with glass shell and stainless steel cover.

When assembling and using the heat exchanger, please observe the following points:

- Every piece of apparatus is supplied with assembly and operating instructions, which must be read carefully before the equipment is installed and put into operation. When affixing using angled feet, pay special attention to ensure that there is a fixed point and a free point.
- The shell and tube heat exchanger's media filter nozzles should be connected so that they are free of tension, and with compensators.
- When installing, pay attention to the weights given.
- The standard design heat exchangers are intended for horizontal use. Optional vertical designs are also possible. Please specify this when ordering, on the basis of the option mentioned above.
- When in operation, as well as observing the permissible operating conditions, ensure that thermal shocks (max 130 K allowed) and pressure surges are avoided.
- Cleaning and maintenance work should only be carried out according to the operating instructions. You can use dummy plugs and spare tubes/screw connections for any repairs needed. Repairs should only be undertaken by trained personnel, and according to the assembly and operating instructions.

Please contact our specialist department if you have any questions.



### OPTIONS FOR HST SHELL AND TUBE HEAT EXCHANGERS

There are numerous options available for the HST shell and tube heat exchanger. These are characterised by the suffix -OST at the end of the respective item number.

Choose option -OST1 for a vertical heat exchanger assembly. In this design, the heat exchanger's mounting and the securing of the individual tubes are adapted accordingly. Complete draining/ventilation is also optionally possible, on the basis of the diagram shown. Details on this, specific to your enquiry, can be agreed with our specialists.

A double sealing system, using a leakage chamber as per option -OST2 separates the product and the cooling/heating medium by means of an additional security space. In the event of a leak via the base plate seal to the respective heat exchanger tube, cross-contamination is avoided. This means that the cooling medium cannot enter the product area, and vice versa. For monitoring purposes, a glass collection tube is fitted to the interspace. Any possible leaks run into here, meaning that they are visible.

The design with a stainless steel counterplate allows increased permitted operating pressure at the tube side. The standard design uses O-rings made from FEP for the double seal mechanism. However, other sealing materials can be optionally used.

The 'baffle plate' option enables overheated steam that is heated to a local overheated temperature to lead to a heat exchange tube or the tube-side medium.

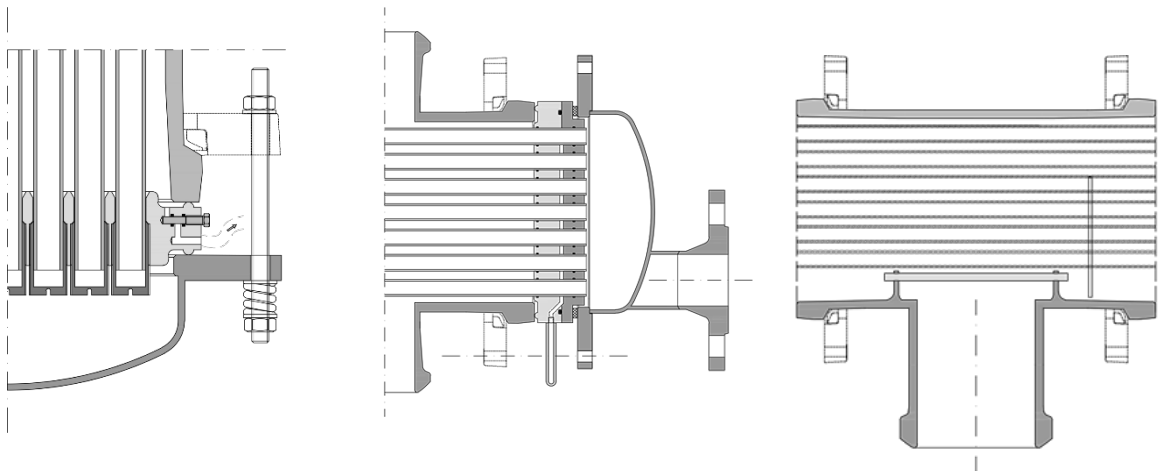

Option OST1:  
Drainage/ventilation  
when installed vertically

Option OST2:  
Double seal/Leakage chamber

Option OST3:  
Design with baffle plate for  
overheated steam

As well as the three assemblies shown, and the versions with various different base plates, countless other designs have been made available to meet the specific process requirements of different customers. These include the use of alternative pairs of materials (i.e. -OST4 for the design with enamel shell) or systems for use in clean rooms (option -OST5).

If your particular application presents its own specific demands, please speak to our specialists.

There are a number of steps which can increase the efficiency of shell and tube heat exchangers.

Turbulence promoters (option OST6) made from PTFE/tantalum can improve the transfer of heat by increasing the fluid speed at the tube walls to a turbulent current. Turbulence promoters tend to increase performance particularly in heat exchangers where the tube-side liquid has a relatively low tempering medium speed and increased viscosity. We are able to create custom treatments for your application, and adapt the pitch of the coil according to specific fluid speeds.



Option OST6: Turbulence promoter 'Twisted tape'

Shell-side process control using helix baffles (option OST 7) made from PTFE can minimise dead space in the flow system, and optimise flow speeds. This ensures that, on the one hand, heat exchange is improved, and on the other, the susceptibility to contamination is reduced. Helical baffles are especially beneficial when used with shell-side liquids that determine the heat exchange. They also have the advantage of being able to increase the flow speed at the waste gas side and guide the flow when used with condensers.

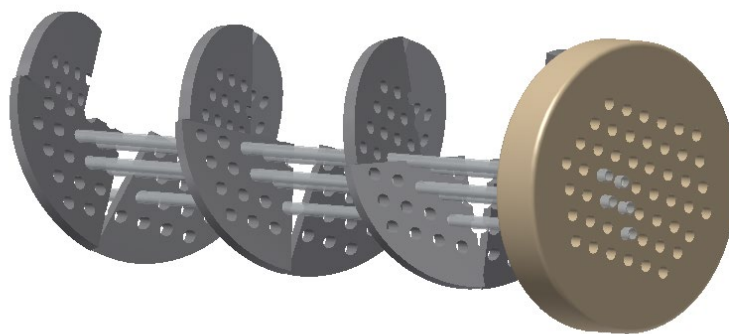

Option OST7: guided baffle 'Helix baffle'

By using a longitudinal baffle (option OST8) made from PTFE/tantalum/borosilicate 3.3, a more targeted countercurrent flow is possible. This means that, for the appropriate process requirements, increased efficiency is possible due to the temperature more closely approaching that of the media being used's respective inlet temperatures. The two following diagrams depict designs for liquid-liquid transfer and condensation using a longitudinal baffle. For the design for use with condensation, it is also possible to fit the longitudinal baffle off-centre.

To complement the longitudinal baffles, we also provide meandering baffles, which on the one hand stabilise the tube, and on the other, lead to a targeted increase in the flow speed in the direction of the longitudinal baffle.

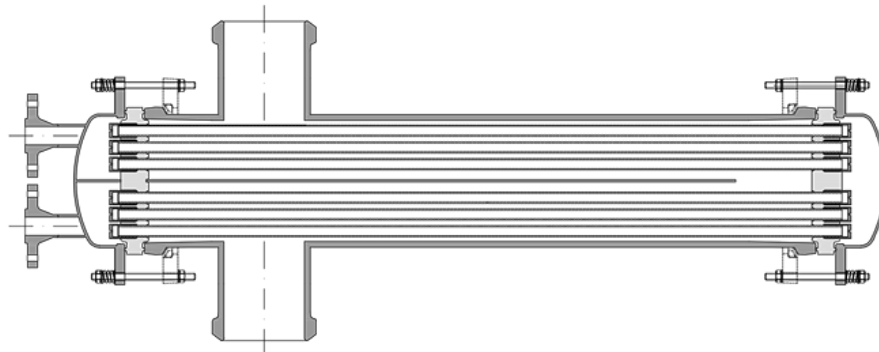

Option OST8: Longitudinal baffle for the liquid-liquid heat exchanger design

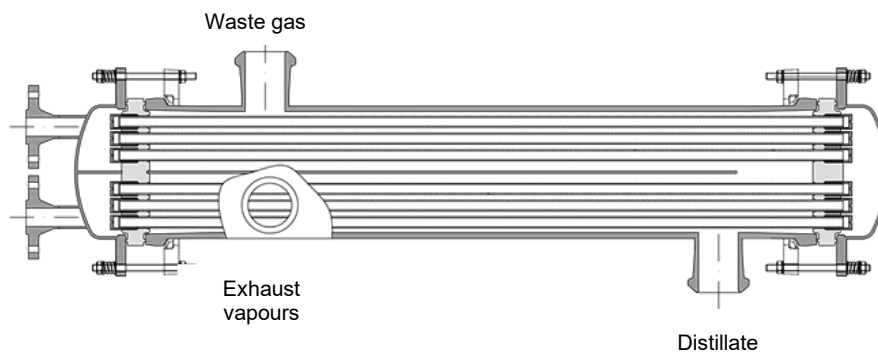

Option OST8: Longitudinal baffle for the condensation heat exchanger design

Special design -OST9 is an adaptation of the system with longitudinal baffle for condensation that makes integrated post-condensation possible. The main condensation occurs using cooling water as the coolant in the counterflow, with a distillate outlet at the cooling water inlet nozzle. The remaining non-condensed gases rise at the longitudinal baffle, where they are post-condensed with a colder cooling medium, similarly in the counterflow. The remaining non-condensable gases escape through the top waste gas nozzle, while the post-condensed liquid flows out of the distillate nozzle.

This variant is only available with a double seal system with leakage chamber, so as to ensure that both cooling media areas and the product area are kept securely away from each other.

The main advantage of this variant is the combined, space-saving construction method for processes that require both condensation and post-condensation.

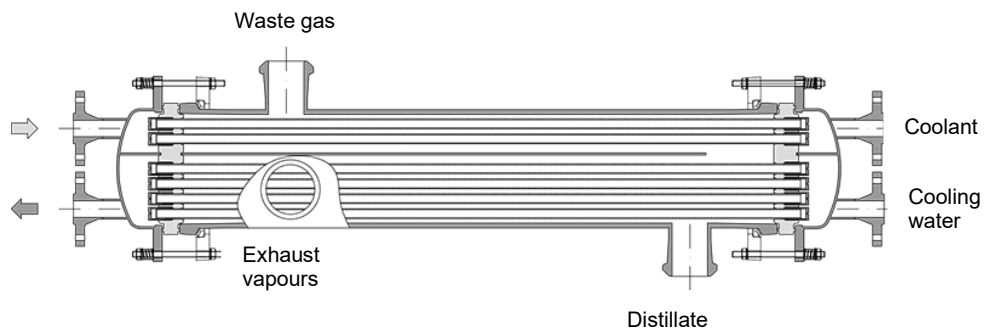

Option OST9:  
Longitudinal baffle for the condensation heat exchanger design, with integrated post-condensation

## SHELL AND TUBE EXCHANGER HST10

As well as all the measures for increasing efficiency using built-in and more targeted process control, the HST10 'high efficiency shell and tube heat exchanger' has also been introduced. Smaller tubes with an external diameter of 10mm were deliberately used in this shell and tube heat exchanger. This ensures that there is a larger exchange area with heat exchanger dimensions that are otherwise the same. It also offers increased heat transfer thanks to the thinner-walled tubes that also provide increased strength as well as lower pressure loss at the tube side with the same flow speed / transfer area..

A comparison of the HST and HST10 designs can be found in the following table.

In principle, all previously mentioned options are also possible with the HST10, with the exception of SiC tubes.

	Type	Tubes [Pcs]	ØTube [mm]	Perm. op. press.		Perm. temp. [°C]	Area/Length [m <sup>2</sup> /m length]	Tube area* [cm <sup>2</sup> ]
				Tube [BarG]	Shell BarG]			
DN100	HST	13	Ø14 x 1.5	-1/+3	-1/+2	-50/+150	0.57	12
	HST10	31	Ø10 x 1.0	-1/+4	-1/+2	-50/+150	0.97	16
DN150	HST	37	Ø14 x 1.5	-1/+3	-1/+2	-50/+150	1.62	35
	HST10	73	Ø10 x 1.0	-1/+4	-1/+2	-50/+150	2.29	37
DN200	HST	74	Ø14 x 1.5	-1/+3	-1/+2	-50/+150	3.25	70
	HST10	142	Ø10 x 1.0	-1/+4	-1/+2	-50/+150	4.46	71

\* For 1-Kass design

Specific dimensions for the standard shell and tube heat exchanger HST10 are listed below. These are based on the type with 1-Kass stainless steel cover and similar distance of baffles. Dimensions are corresponding to the drawing of the "shell and tube exchanger HST ...-K" on a previous page.

Area [m <sup>2</sup> ]	DN	DN1*	DN2	DN3	DN4	L [mm]	L1 [mm]	L2 [mm]	L3 [mm]	L4 [mm]	L5 [mm]	Item-no.
0.6	100	25	50	25	25	900	250	400	150	150	175	<b>HST10 100/006/422/GS1-K</b>
1.0	100	25	50	25	25	1,300	250	800	150	150	175	<b>HST10 100/010/422/GS1-K</b>
1.5	100	25	80	25	25	1,800	275	1,250	150	150	175	<b>HST10 100/015/522/GS1-K</b>
2.5	100	25	80	25	25	2,850	275	2,300	150	150	175	<b>HST10 100/025/522/GS1-K</b>
1.5	150	25	80	25	25	900	250	350	175	175	175	<b>HST10 150/015/522/GS1-K</b>
2.5	150	25	100	50	50	1,350	300	750	175	175	200	<b>HST10 150/025/644/GS1-K</b>
3.5	150	25	100	50	50	1,800	300	1,200	175	175	200	<b>HST10 150/035/644/GS1-K</b>
4.5	150	25	100	50	50	2,250	300	1,650	175	175	200	<b>HST10 150/035/644/GS1-K</b>
6.0	150	25	100	50	50	2,850	300	2,250	175	175	200	<b>HST10 150/060/644/GS1-K</b>
5.0	200	50	150	80	50	1,450	375	700	200	175	250	<b>HST10 200/050/754/GS1-K</b>
7.0	200	50	150	80	50	1,900	375	1,250	200	175	250	<b>HST10 200/070/754/GS1-K</b>
9.0	200	50	150	80	50	2,350	375	1,600	200	175	250	<b>HST10 200/090/754/GS1-K</b>
11.0	200	50	150	80	50	2,800	375	2,100	200	175	250	<b>HST10 200/110/754/GS1-K</b>

\* Flange type according to EN 1092-1 PN 10. Other flange types available on request.

## JACKETED TUBE HEAT EXCHANGER

Jacketed tube heat exchangers are predominantly used for heating and cooling liquid media. Fundamental details are the combination of excellent heat transfer thanks to SiC and universal chemical resistance to products due to the use of SiC and PTFE. They also boast high flow speeds at low dwell times and their design minimises dead space. The tempering jacket is made from stainless steel.

The standard operating conditions for the standard design are  $-1/+6$  BarG and  $-50/+200^{\circ}\text{C}$ .

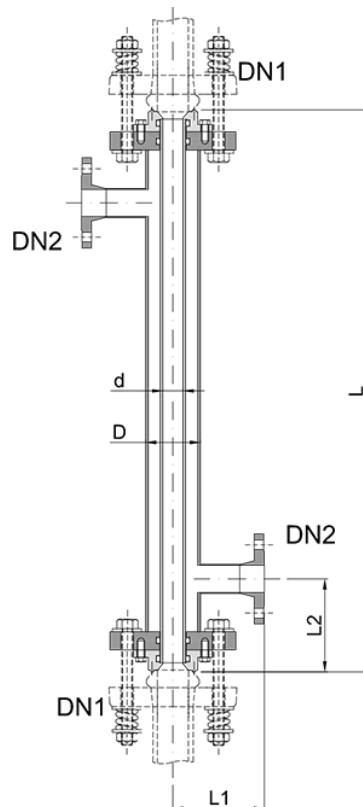

Jacketed tube heat exchanger HM...-K

### Descriptions:

Jacketed tube heat exchanger with turbulence promoter:

Item number

HM...-K-O6

Example

HM 15/1000-K-O6

Jacketed tube heat exchanger with guide spiral shell:

HM...-K-O7

HM 15/1000-K-O7

Jacketed tube heat exchanger with 3.1 material certificate:

HM...-K-Z1

HM 15/1000-K-Z1

Area [m <sup>2</sup> ]	DN1	DN2	L [mm]	L1 [mm]	L2 [mm]	d [mm]	D [mm]	Item no.
0.02	15	15	500	75	75	14 x 1.5	29.7 x 1.6	<a href="#">HM 015/0500-K</a>
0.04	15	15	1,000	75	75	14 x 1.5	29.7 x 1.6	<a href="#">HM 015/1000-K</a>
0.07	15	15	1,500	75	75	14 x 1.5	29.7 x 1.6	<a href="#">HM 015/1500-K</a>
0.09	15	15	2,000	75	75	14 x 1.5	29.7 x 1.6	<a href="#">HM 015/2000-K</a>
0.04	25	25	500	75	50	20 x 1.5	29 x 1.5	<a href="#">HM 025/0500-K</a>
0.08	25	25	1,000	75	50	20 x 1.5	29 x 1.5	<a href="#">HM 025/1000-K</a>
0.12	25	25	1,500	75	50	20 x 1.5	29 x 1.5	<a href="#">HM 025/1500-K</a>
0.16	25	25	2,000	75	50	20 x 1.5	29 x 1.5	<a href="#">HM 025/2000-K</a>

COOLING TRAP

Cooling traps are used for condensing smaller amounts of liquid from a gas stream, for example, the remnants of solvents in a waste gas pipe or vacuum pipe. The gas stream is diverted into the cooling trap's inner cylinder, which is filled with either liquid nitrogen or dry ice, where it is cooled down extensively. Condensate drips from the tip of the cylinder into the cooling trap's lower area, which catches a small amount of condensate. To avoid renewed vaporisation, the condensate should be drained regularly or continuously.

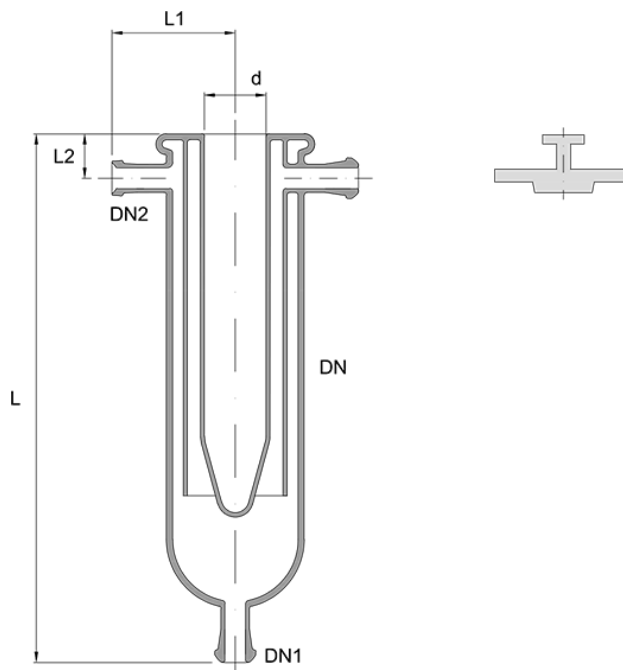

Cold trap HCT...-K

Option: PP cap

Descriptions:

- Cooling trap, PF system, conductive coating:
- Cooling trap, PF system, with 2.1 material certificate:
- Cooling trap, PF system, with PP cap

Item number	Example
HCT....-K-C3	HCT 150/07-K-C3
HCT....-K-Z2	HCT 150/07-K-Z2
HCT....-K-O4	HCT 150/07-K-O4

Area [m <sup>2</sup> ]	DN	DN1	DN2	L [mm]	d [mm]	L1 [mm]	L2) [mm]	Volume* [l]	Item no.
0.05	100	25	25	450	55	110	50	0.4	<b>HCT 100/05-K</b>
0.1	150	25	25	535	90	150	60	2.1	<b>HCT 150/10-K</b>
0.2	200	25	25	685	144	175	60	7.2	<b>HCT 200/20-K</b>
0.35	300	25	25	720	215	225	70	18	<b>HCT 300/35-K</b>

\* Volume of cold liquid

HEATING MANTLE, ELECTRICAL

Heating mantles are divided into several different heating zones. The surface temperature of the various different heating zones is monitored individually by temperature sensors. The optionally available control unit enables you to avoid local overheating. Heating mantles are available in various different sizes, for both spherical and cylindrical vessels.

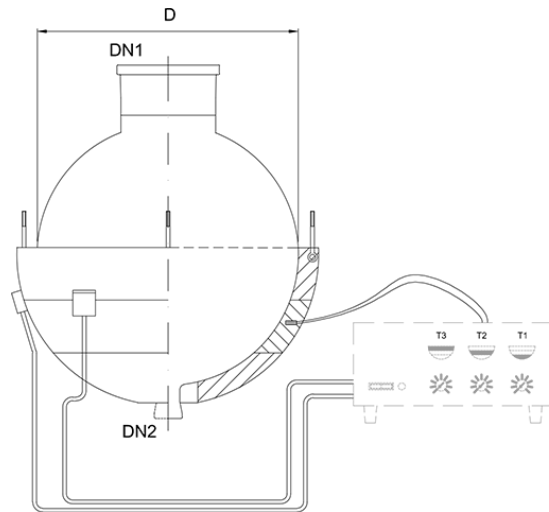

HHC heating mantle for spherical vessel

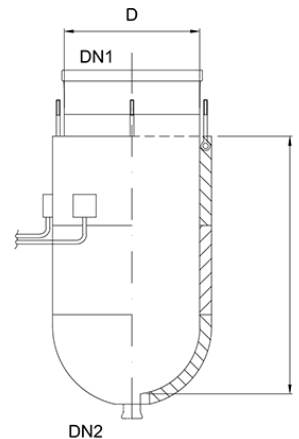

HHJ heating jackets for cylindrical vessel

Descriptions:

Heating mantle, ATEX design, II 3G Ex IIA T1:

Heating mantle for spherical vessels old dimensions:

Item number

HHC....-O8

HHC....-O10

Example

HHC 200-O8

HHC 200-O10

Sphere vol. [Liter]	Output [kW]	DN1	DN2	D [mm]	Item no.
10	1.6	100	25	280	<b>HHC 010</b>
20	2.4	100	25	350	<b>HHC 020</b>
50	4.5	200	25	490	<b>HHC 050</b>
100	6.0	200	50	610	<b>HHC 100</b>
200	9.0	300	50	750	<b>HHC 200</b>

Cylinder vol. [Liter]	Output [kW]	DN1	DN2	D [mm]	L [mm]	A [m <sup>2</sup> ]	Item no.
10	1,6	200	25	215	380	0,25	<b>HHJ 010</b>
20	2,4	300	25	315	330	0,32	<b>HHJ 020</b>
30	4,5	300	25	315	475	0,47	<b>HHJ 030</b>
50	4,5	300	50	315	725	0,71	<b>HHJ 050</b>
100	6,0	400	50	415	825	1,07	<b>HHJ 100/400</b>
100	6,0	450	50	465	705	1,03	<b>HHJ 100/450</b>
150	6,0	400	50	415	1.215	1,58	<b>HHJ 150/400</b>
150	6,0	450	50	465	1.010	1,47	<b>HHJ 150/450</b>
200	9,0	450	50	465	1.315	1,92	<b>HHJ 200</b>



**Fragebogen zur Wärmeübertrager-Auslegung / Questionnaire heat exchangers**

- Anwendung / application:     Kondensation / condensation  
     Flüssig-flüssig-Wärmeübertragung / liquid-liquid heat transfer  
     andere /other

**Wärmeübertragungsfläche / Heat exchange area \*:** \_\_\_\_\_[m<sup>2</sup>]

**Prozessdaten / Process data \*\*:**

	Einheit / Unit	Prozessmedium / Process fluid	Temperiermedium / Cooling or heating fluid
Bezeichnung und Konzentration / Description and concentration			
Durchflussmenge / Flow rate	[kg/h]		
Eintrittstemperatur / Inlet temperature	[°C]		
Austrittstemperatur / Outlet temperature	[°C]		
Eintrittsdruck / Inlet pressure	[ bar (a)]		
Spez. Wärmekapazität / Spec. thermal capacity	[kJ/kg K]		
Verdampfungsenthalpie / Evaportaion enthalpy	[kJ/kg]		
Wärmeleitfähigkeit / Thermal conductivity	[W /m K]		
Dyn. Viskosität / Dynamic viscosity	[mPa s]		
Dichte (flüssig) / Density (liquid)	[kg/m <sup>3</sup> ]		
Dichte (gasförmig) / Density (gas)	[kg/m <sup>3</sup> ]		
Anschlussstutzen / Nozzles	[DN]		

**Anmerkungen / Additional information:**

---



---



---



---

**Kunde / Customer:**

Unternehmen / Company:	Datum / Date:
Bearbeiter / Person responsible:	Tel. Nr. / Tel. No.:
Ihre Referenznr / Your Reference No.:	e-mail:

**An / To:** Pfaudler Normag Systems GmbH    Tel.:+49 (0)3677/ 2079-0    E-Mail: sales-normag@pfaudler.com

\* - sofern bekannt angeben / fill in if available

\*\* - Prozessdaten sind für eine detaillierte Auslegung erforderlich. Sollte eine Charakterisierung der Prozessdaten nicht möglich sein, sprechen Sie bitte unsere Fachabteilung an. /Process data is required for a detailed design of the heat exchanger. If the process data cannot be characterized, please contact our specialists.

## OPTIONS HEAT EXCHANGERS

To complement the standard components, the following heat exchanger options can also be chosen. Each option chosen must be entered at the end of the item number. Several options can be chosen, and as far as possible, they are presented in alphabetical order. In the following table you will find examples of item numbering, which include additional options.

<b>Description:</b>	<b>Item no.</b>	<b>Example</b>
Heat exchanger, PF system, dimensions of the old design:	HC....-K-O10	HC 300/40-K-O10
Heat exchanger, PF system, conductive coating:	HC....-K-C3	HC 300/40-K-C3
Heat exchanger, PF-system, with 2.1 material certificate:	HC....-K-Z2	HC 300/40-K-Z2

You can choose from the following options:

### OPTION C – COATING/GLASS TYPE

The standard components used are those made of borosilicate glass 3.3 without a coating. The following alternative options are possible:

- C1 = coating, non-conductive
- C2 = coating, non-conductive, for higher temperatures and chemical resistance
- C3 = coating, conductive
- C4 = amber glass
- C5 = quartz glass

### OPTION F – FLANGE TYPE

The standard components used are made of borosilicate glass 3.3 with the flange type F4 (PF system). The following flange connectors for glass structural components are also generally available:

- F1 = KF flanges, type KF../1
- F2 = KF flanges, type KF../2
- F3 = KF flanges, type KF../3
- F4 = PF flanges, type PF
- F5 = Tube connection 16 mm
- F6 = Tube connection 26 mm
- F7 = GL-thread GL 18
- F8 = GL-thread GL 25
- F9 = NS 29/32
- F10 = NS 45/40

All other combinations of the flange types F1 to F4 can be selected as options.

We will be glad to check whether the other types of flange can be used with the selected component.

**OPTION M – MATERIAL/PTFE DESIGN**

The standard shell and tube heat exchanger design is in white PTFE, non-conductive and with no material certificate.

M1 = PTFE conductive

M2 = PTFE conductive with earthing lug

The option M choice selection only applies to shell and tube heat exchangers.

**OPTION O – SPECIAL Descriptions**

The following special options are offered for certain structural components.

O1 = Outlet nozzles DN 40 for immersion heat exchangers

O2 = Outlet nozzles with minimum dead space, for immersion heat exchangers' bottom outlet valve

O3 = Mirrored arrangement of waste gas nozzles for reflux and flow condensers

O4 = Additional PP cap with handle for cold traps

O5 = Flow condenser with vertical distillate/waste gas nozzles

O6 = Jacketed tube heat exchanger with turbulence promoter

O7 = Jacketed tube heat exchanger with guide spiral shell

O8 = Heating mantle, ATEX design, II 3G Ex IIA T1

O10 = Dimensions according to former design

OST1 = Shell and tube heat exchanger HST, vertical design

OST2 = Shell and tube heat exchanger HST, with leakage chamber

OST3 = Shell and tube heat exchanger HST, with baffle plate for steam

OST4 = Shell and tube heat exchanger HST, with enamel shell

OST5 = Shell and tube heat exchanger HST, with clean room design

OST6 = Shell and tube heat exchanger HST, with turbulence promoter

OST7 = Shell and tube heat exchanger HST, with helical baffles

OST8 = Shell and tube heat exchanger HST, with longitudinal baffle

OST9 = Shell and tube heat exchanger HST, with longitudinal baffle and post-condenser

**OPTION SP – SPARE PARTS**

We would be happy to supply you with spare parts upon request.

**OPTION TAG – LABELLING**

Standard labelling of glass structural components is carried out using the standard item number or special identification number, however without an individual TAG number.

TAG numbering is available for the purposes of individual numbering. To do this, enter the option TAG and provide us with the desired TAG number.

TAG = with TAG numbering

**OPTION Z – CERTIFICATES**

Standard deliveries do not come with certificates.

The following certificates can optionally be delivered with your order.

Z1 = FDA material certificate<sup>1)</sup>

Z2 = Material certificate 2.1

Z3 = Certificate for Technical Guidelines on Air Quality Control (TA-Luft)

1) FDA material certificates can be delivered for product-side structural components containing PTFE.